

# XFP-DW10GTU-40C

10Gbps Tunable DWDM XFP Transceiver, Single Mode, 40km Reach



## Product Features

- ❖ Supports 9.95Gb/s to 11.3Gb/s transmission
- ❖ Client side and Line side loopback functions
- ❖ XFP MSA compliant form factor connector
- ❖ XFI electrical interface compliant
- ❖ Hot-pluggable XFP footprint
- ❖ 40km MZM Tunable TOSA
- ❖ Supports 50GHz ITU-based channel spacing (C-Band) ,cover 80 ITU-based channel

- ❖ With wavelength locker function, wavelength precision about 0.02nm
- ❖ Power Dissipation < 3.5W
- ❖ I2C interface for diagnostic monitoring
- ❖ Operation Temperature: 0~70° C
- ❖ RoHS 6 Compliant

## Applications

- ❖ DWDM 10Gb/s SONET/SDH
- ❖ DWDM 10Gb/s SONET/SDH with FEC
- ❖ DWDM 10Gb/s Ethernet & 10G Fiber Channel
- ❖ DWDM 10Gb/s Ethernet & 10Gb/s Fiber Channel with FEC

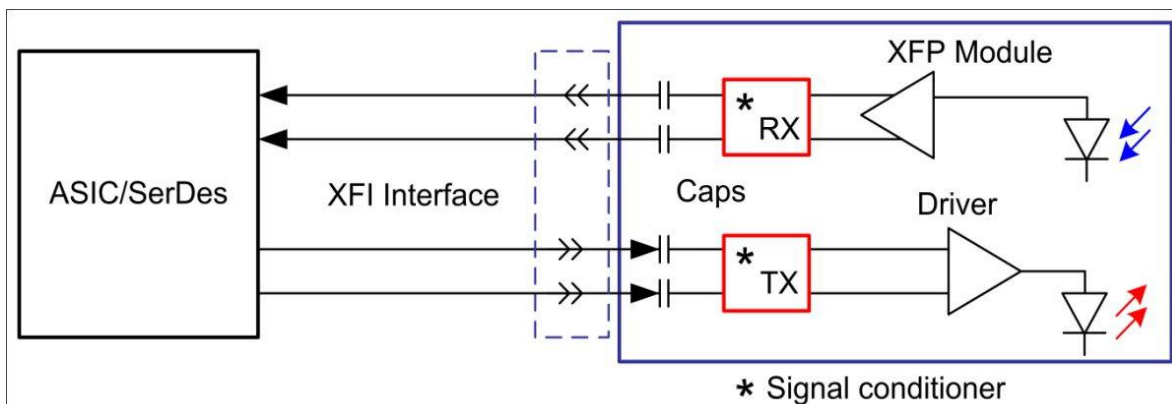

**Application in System**

## General Description

The XFP-DW10GTU-40C series optical transceiver is a high performance and cost effective XFP transceiver modules designed for 10G SDH/SONET, 10G Ethernet DWDM fiber optic transmission applications, designed to support the full range of C-band ITU-T wavelengths data rates from 9.95Gbps to 11.3Gbps and distances up to 40km.

This transceiver contains both transmit and receive sections. An MZM, (C-band tunable laser with a wavelength locker) a laser driver and the supporting circuits constitute the transmit path while an APD ROSA, a post amplifier and the supporting circuits form the receive section. A microcontroller handles the communications between the module and the host board as well as the control and monitoring functions for both transmit and receive sections. A Clock and Data Recovery circuit (CDR) functions for both transmit and receive.

The transceiver module is fully compliant with the XFP MSA standard and can be hot-plugged into the 30-pin XFP connector on the host board. By limiting inrush currents, the device will not disturb the operations of the host board. The high-speed electrical interface is fully compliant with the XFI standard, providing transmission paths for the 10G signals.

## Functional Description

The XFP-DW10GTU-40C series optical transceiver contains a duplex LC connector for the optical interface and a 30-pin connector for the electrical interface.

The transceiver module receives 10Gb/s electrical data and convert it to an optical signal. The transmitter contains a Clock Data Recovery (CDR) circuit that reduces the jitter of received signal and reshapes the electrical signal before the electrical to optical (E-O) conversion. The optical output power is maintained constant by an automatic power control (APC) circuit. The transmitter output can be turned off by TX disable signal at TX\_DIS pin. When TX\_DIS is asserted high, the transmitter is turned off.

The received optical signal is converted to serial electrical data signal. The optical receiver contains a CDR circuit that reshapes and retimes an electrical signal before sending out to the XFI channel (i.e. XFP connector and high speed signal traces). The RX\_LOS signal indicates insufficient optical power for reliable signal reception at the receiver.

A 2-wire interface (SCL, SDA) is used for serial ID, digital diagnostics and other control/monitor functions. The address of XFP transceiver is 1010000x. MOD\_DESEL signal can be used to support multiple XFP modules on the same 2-wire interface bus. Management interface is compliant with XFP MSA.

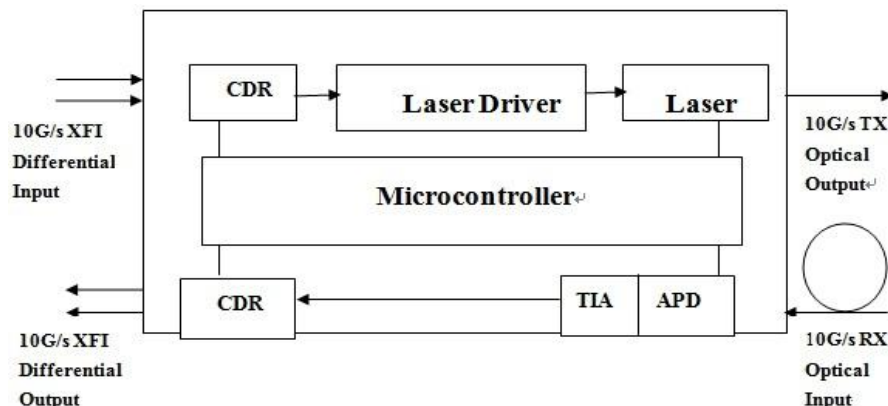

Transceiver Block Diagram

## Absolute Maximum Ratings

Parameter	Symbol	Min	Max	Unit	Note
Storage Temperature	Tst	-40	85	degC	
Relative Humidity (non-condensation)	RH	-	85	%	
Operating Case Temperature	Topc	0	70	degC	1
Supply Voltage #3	VCC3	-0.5	3.6	V	
Supply Voltage #5	VCC3	-0.5	6.0	V	
Voltage on LVTTTL Input	Vilvttl	-0.5	VCC3+0.5	V	
LVTTTL Output Current	Iolvttl	-	15	mA	
Voltage on Open Collector Output	Voco	0	6	V	
Receiver Input Optical Power(Average)	Mip	-	-7	dBm	2

**Notes:**

1. Ta: -10 to 60degC with 1.5m/s airflow with an additional heat sink.
2. APD Receiver.

## Recommended Operating Conditions & Power Supply Requirements

Parameter	Symbol	Min	Max	Unit
Operating Case Temperature	Topc	0	70	degC
Relative Humidity (non-condensing)	Rhop	-	85	%
Power Supply Voltage #3	VCC3	3.135	3.465	V
Power Supply Current #3	ICC3	-	750	mA
Power Supply Voltage #5	VCC5	4.75	5.25	V
Power Supply Current #5	ICC5	-	300	mA
Power Supply Voltage #2	VCC2	1.71	1.91	V
Power Supply Current #5	ICC5	-	500	mA
Total Power Consumption	Pd	-	3.5	W

## Low Speed Control & Alarm Signals Electrical Interface

Parameter	Symbol	Min	Max	Units	Note
XFP Interrupt, Mod_NR, RX_LOS	V <sub>ol</sub>	0.0	0.4	V	1
	V <sub>oh</sub>	V <sub>cc</sub> -0.5	V <sub>cc</sub> +0.3		2
XFP TX_DIS, P_DOWN/RST	V <sub>il</sub>	-0.3	0.8	V	3
	V <sub>ih</sub>	2.0	V <sub>CC3</sub> +0.3		4
XFP SCL and SDA Output	V <sub>ol</sub>	0.0	0.4	V	1
	V <sub>oh</sub>	V <sub>cc</sub> -0.5	V <sub>cc</sub> +0.3		2
XFP SCL and SDA Input	V <sub>il</sub>	-0.3	V <sub>CC3</sub> *0.3	V	5
	V <sub>ih</sub>	V <sub>CC3</sub> *0.7	V <sub>CC3</sub> +0.5		6
Capacitance for XFP SCL and SDA I/O pin	C <sub>i</sub>	-	14	pF	
Total bus capacitive load for SCL and SDA	C <sub>b</sub>	-	100	pF	7
			400	pF	8

**Notes:**

1. Pull-up resistor must be connected to host\_Vcc on the host board. I<sub>ol</sub>(max)=3mA
2. Pull-up resistor must be connected to host\_Vcc on the host board.
3. Pull-up resistor connected to VCC3 within XFP module. I<sub>il</sub>(max)= -10μA.
4. Pull-up resistor connected to VCC3 within XFP module. I<sub>ih</sub>(max)= 10μA.
5. Pull-up resistor must be connected to host\_Vcc on the host board. I<sub>ol</sub>(max)= -10μA.
6. Pull-up resistor must be connected to host\_Vcc on the host board. I<sub>ol</sub>(max)= 10μA.
7. At 400KHz, 3.0kohms pull-up resistor, at 100kHz 8.0kohms pull-up resistor max.
8. At 400KHz, 0.8kohms pull-up resistor, at 100kHz 2.0kohms pull-up resistor max.

## Optical Interface

Parameter	Symbol	Min	Typical	Max	Unit	Note
<b>Transmitter Optical Interface</b>						
Operating Data Rate	-	9.95		11.30	Gb/s	1
Wavelength range (ITU Grid)	$\Lambda$	1528.77		1563.86	nm	
Transmitter Center Wavelength – End Of Life	$\lambda_c$	$\lambda_c - 2.5$	$\lambda_c$	$\lambda_c + 2.5$	GHz	
Crossing Ratio		40		60	%	
Center Wavelength Spacing			50		GHz	
SMSR	SMSR	30		-	dB	
Wavelength tuning (Cold Start)				30	s	
Wavelength tuning (Warm)			0.5	2	s	
Average Output Power	Po	-1		+3	dBm	2
Dispersion Penalty @9.95G	DP			2	dB	2
Dispersion Penalty @10.3125G	DP			2.5	dB	3
Disabled Power	Poff	-		-30	dBm	2
Extinction Ratio	ER	9.0	10	-	dB	2
Eye Mask 1 (SONET/SDH)		GR-253-CORE/ITU-T G.691				2
Eye Mask 2 (10G Ethernet)		IEEE802.3ae				3
Spectral Width (-20dB from Peak)	FW20		0.25		nm	
RIN	RIN	-		-130	dB/Hz	
<b>Receiver Optical Interface</b>						
Operating Data Rate		9.95		11.30	Gb/s	1
Input Center Wavelength	lrc	1250		1620	nm	
Overload	Rovl	-7.0		-	dBm	
Minimum Sensitivity	Pmin	-		-15.8	dBm	2
LOS Assert	LOSA	-29			dBm	
LOS Deassert	LOSD			-18	dBm	
LOS Hysteresis	LOSH	0.5			dB	
Optical Path Penalty	PN	-		TBD	dB	1
Optical Return Loss	ORL	26		-	dB	
Jitter Tolerance	JTL	GR-253-CORE/ITU-T G.783				

**Notes:**

1. Data rate tolerance:

- IR-2/S-64.2b, 10GBASE-EW: typ. +/-20ppm
- 10GBASE-ER: typ. +/-100ppm
- 2. Measured at 9.95Gbps, Non-framed PRBS2^31-1, NRZ
- 3. Measured at 10.3125Gbps, Non-framed PRBS2^31-1, NRZ

## Digital Diagnostic Functions

Parameter	Symbol	Min	Max	Unit	Notes
Temperature monitor absolute error	DMI_Temp	-3	3	degC	Over operating temp
Laser power monitor absolute error	DMI_TX	-3	3	dB	
RX power monitor absolute error	DMI_RX	-3	3	dB	-1dBm to -15dBm range
Supply voltage monitor absolute error	DMI_VCC	-0.1	0.1	V	Full operating range
Bias current monitor	DMI_Ibias	-10%	10%	mA	

## Pin Assignment and Pin Description

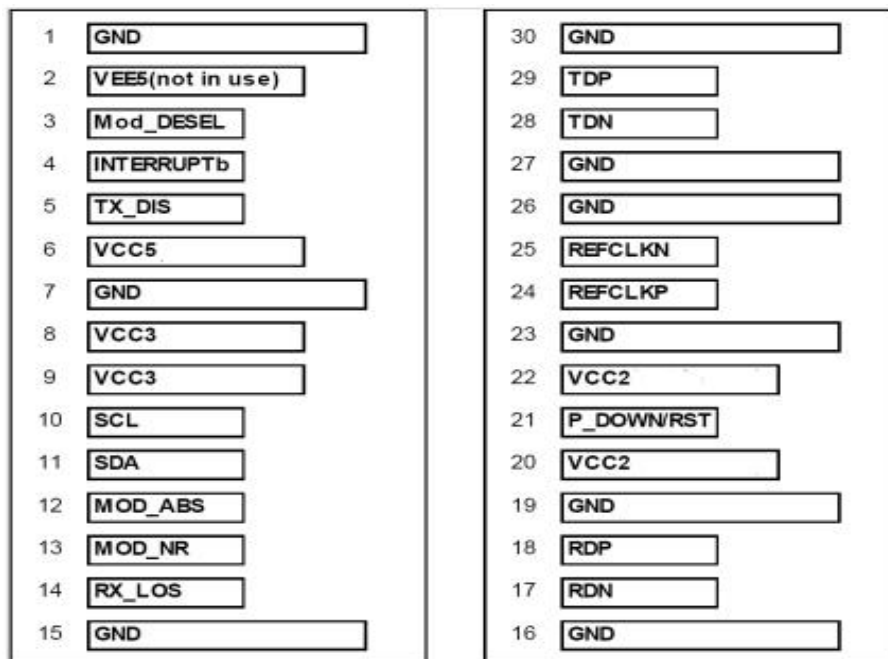

Bottom View

Top View

## Pin Descriptions

Pin#	Name	Logic	Description	Note
1	GND		Module Ground	1
2	VEE5		-5V Power Supply , not in use	3
3	MOD_DESEL	LVTTL-I	Module De-select; When held Low allows module to respond to 2-wire serial interface	
4	INTERRUPT	LVTTL-O	Indicates presence of an important condition, which can be read over the 2-wire serial interface. This pin is an open collector output and must be pulled up to host_Vcc on the host board.	2
5	TX_DIS	LVTTL-I	Transmitter Disable; When asserted High, transmitter output is turned off. This pin is pulled up to VCC3 in the module	
6	VCC5		+5V Power Supply	3
7	GND		Module Ground	1
8	VCC3		+3.3V Power Supply	
9	VCC3		+3.3V Power Supply	
10	SCL	I/O	2-wire serial interface clock. Host shall resistor connected to host_Vcc of +3.3V.	2
11	SDA	I/O	2-wire serial interface data. Host shall use a pull-up resistor connected to host_Vcc of +3.3V.	2
12	MOD_ABS	LVTTL-O	Indicates Module is not present. Host shall pull up this pin, and grounded in the module. "High" when the XFP module is absent from a host board.	2
13	MOD_NR	LVTTL-O	Module not ready; When High, Indicates Module Operational Fault. This pin is an open collector and must be pulled to host_Vcc on the host board.	2,3
14	RX_LOS	LVTTL-O	Receiver Loss of Signal; When high, indicates insufficient optical input power to the module. This pin is an open collector and must be pulled to host_Vcc on the host board.	2
15	GND		Module Ground	
16	GND		Module Ground	
17	RDN	CML-O	Receiver Inverted Data Output; AC coupled inside the module.	
18	RDP	CML-O	Receiver Non-Inverted Data Output; AC coupled in side the module.	
19	GND		Module Ground	1
20	VCC2		+1.8V Power Supply	
21	P_DOWN/RST	LVTTL-I	Power down; When High, module is limited power mode. Low for normal operation. Reset; The falling edge indicates complete reset of the module. This pin is pulled up to VCC3 in the module. (Power Down function support upon request)	
22	VCC2		+1.8V Power Supply; not in use	



23	GND		Module Ground	1
24	REFCLKP	PECL-I	Reference clock Non-Inverted Input; not in use	
25	REFCLKN	PECL-I	Reference clock Inverted Input; not in use	
26	GND		Module Ground	1
27	GND		Module Ground	1
28	TDN	CML-I	Transmitter Inverted Data Input; AC coupled inside the module.	
29	TDP	CML-I	Transmitter Non-Inverted Data Input; AC coupled inside the module.	
30	GND		Module Ground	1

**Notes:**

1. Module GND pins are isolated from the module case and chassis GND within the module.
2. Shall be pulled up with 4.7k~10kohm to a 3.15V~3.45V on the host board.
3. MOD\_NR = (TX LOL) OR (RX LOL).

## Recommended Power Supply Filter

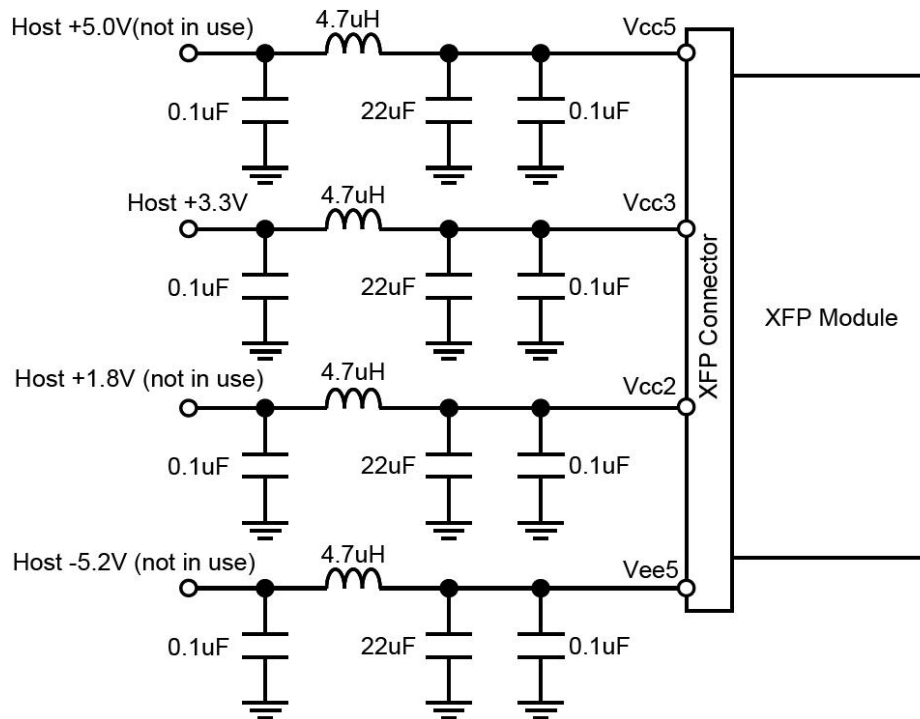

## Recommended Electrical Interface to Host

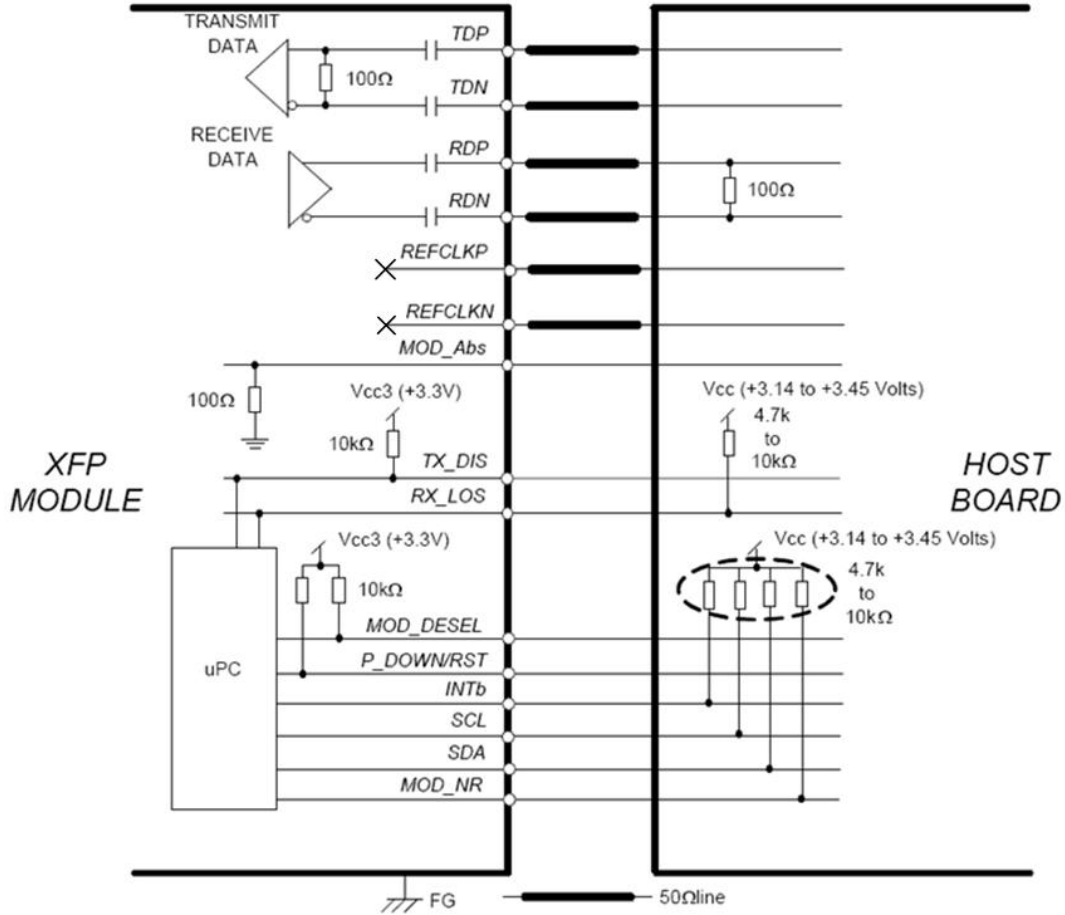

### MSA Compliant EEPROM Structure

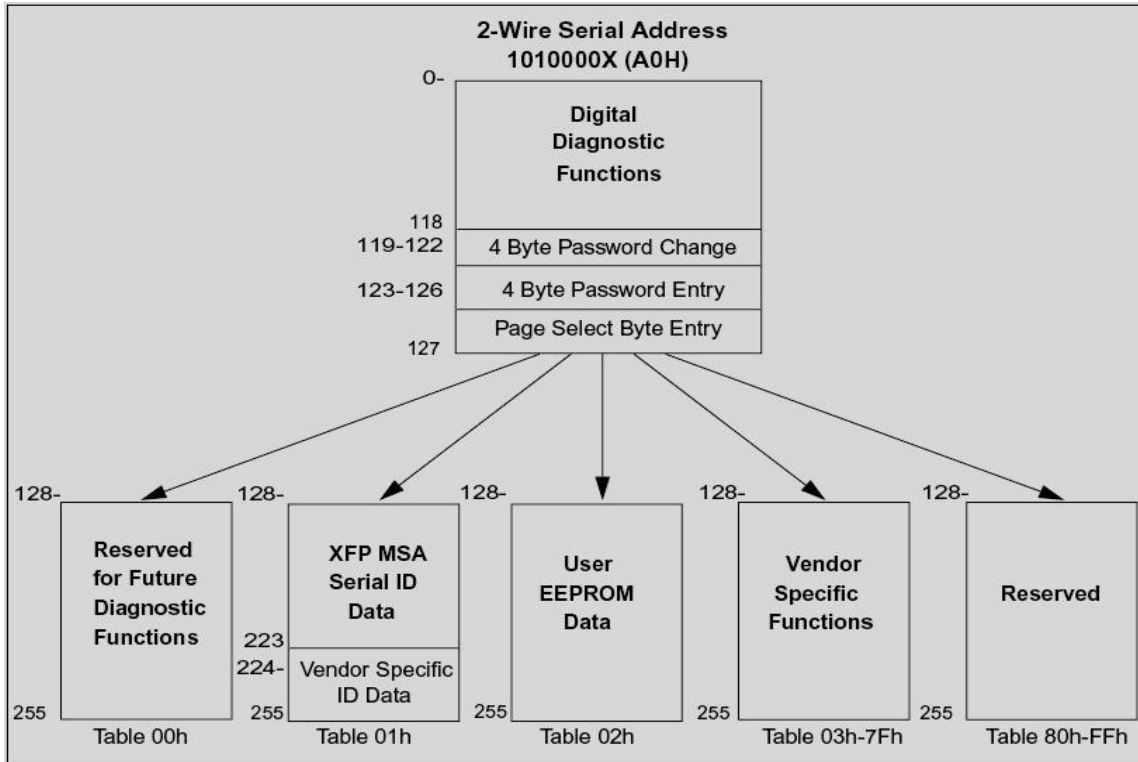

Mechanical Dimensions

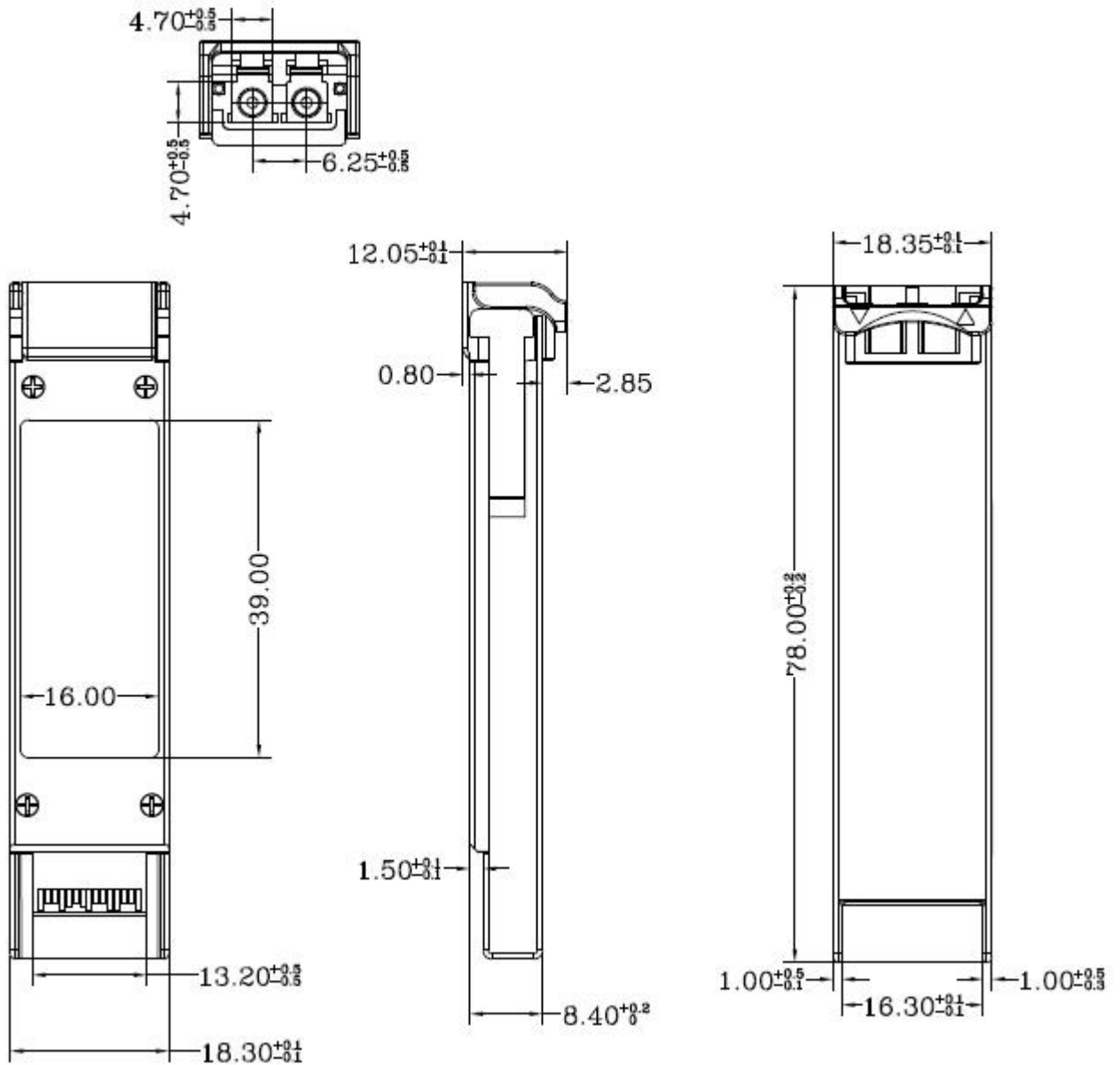

### Ordering Information

Part Number	Product Description
XFP-DW10GTU-40C	10Gbps, DWDM Tunable XFP, 0° C ~ +70° C, LC, 40km, with DDM