

# 10GEPON-OLT-XGS

10G EPON OLT Symmetric XFP PR30 Transceiver



## Product Features

- ❖ Single fiber bi-directional data links TX 10.3125Gbps, Burst Mode RX 10.3125Gbps application
- ❖ Single fiber bi-directional data links TX 1.25Gbps, Burst Mode RX1.25Gbps application
- ❖ 3.3V, 5V power supply
- ❖ XFP package with SC Receptacle connector
- ❖ Hot-pluggable capability
- ❖ High power 1577nm EML LD and High power 1490nm DFB LD

- ❖ High sensitivity 1270nm and 1310nm APD
- ❖ Support 20km transmission distance with SMF
- ❖ LOS indication
- ❖ Low EMI and excellent ESD protection
- ❖ Digital diagnostic monitor interface
- ❖ RoHS6 compliance
- ❖ 0 to 70°C operating case temperature

## Applications

- ❖ Symmetric 10GE PON OLT
- ❖ GE PON PX20+ OLT

## Standards

- ❖ Complies with INF-8077i
- ❖ Complies with IEEE 802.3av
- ❖ Complies with IEEE 802.3ah
- ❖ Complies with FCC 47 CFR Part 15, Class B
- ❖ Complies with FDA 21 CFR 1040.10 and 1040.11

## Absolute Maximum Rating

Parameter	Symbol	Min	Max	Unit	Notes
Storage Ambient Temperature	T <sub>STG</sub>	-40	85	°C	
Operating Case Temperature	T <sub>c</sub>	0	70	°C	
Operating Humidity	OH	5	95	%	
Relative Humidity Storage		5	95	%	
VCC3 Power Supply Voltage	VCC3	-0.5	3.6	V	
VCC5 Power Supply Voltage	VCC5	-0.5	5.5	V	

## Recommended Operating Conditions

Parameter	Symbol	Min	Typical	Max	Unit
Operating Case Temperature	T <sub>c</sub>	0		+70	°C
VCC3 Power Supply Voltage	V <sub>CC3</sub>	3.13	3.3	3.47	V
VCC5 Power Supply Voltage	VCC5	4.75	5	5.25	V
VCC3 Power Supply Current	ICC3 TX		-	500	mA
	ICC3		-	500	mA
	RX				
VCC5 Power Supply Current	ICC5		-	380	mA
Power Consumption	P	-		4	W
Date Rate			10.3125		Gbps
			1.25		Gbps
Date Rate Drift		-100		+100	PPM

## 10G EPON Transmitter Optical Characteristics

Parameter	Symbol	Min	Typical	Max	Unit	Notes
Optical Center Wavelength	$\lambda_C$	1575		1580	nm	
Optical Spectrum Width (-20dB)	$\Delta\lambda$	-	-	1	nm	
Side Mode Suppression Ratio	SMSR	30			dB	
Average Launch Optical Power	AOP	+2		+5	dBm	Launched into SMF
Power-OFF Transmitter Optical Power				-39	dBm	Launched into SMF
Extinction Ratio	ER	6			dB	PRBS 2 <sup>31</sup> -1 @10.3125Gbps
Total Jitter	TJ			0.39	UI	PRBS 2 <sup>31</sup> -1 @10.3125Gbps
Transmitter and Dispersion Penalty	TDP			1.5	dB	Transmit on 20km SMF
Optical Waveform Diagram	Compliant with IEEE Std 802.3av					Figure 1, Mask Margin>5%



**10G EPON Transmitter Electrical Characteristics**

Parameter	Symbol	Min	Typical	Max	Unit	Notes
Data Input Differential Swing		120		850	mV	CML input, AC coupled
Input Differential Impedance		90	100	110	$\Omega$	
Transmitter Enable Voltage - Low		0		0.8	V	
Transmitter Disable Voltage - High		2.0		V <sub>CC</sub>	V	

**GEPON Transmitter Optical Characteristics**

Parameter	Symbol	Min	Typical	Max	Unit	Notes
Optical Center Wavelength	$\lambda_C$	1480		1500	nm	
Optical Spectrum Width (-20dB)	$\Delta\lambda$		-	1	nm	
Side Mode Suppression Ratio	SMSR	30			dB	
Average Launch Optical Power	AOP	+2		+7	dBm	Launched into SMF
Power-OFF Transmitter Optical Power				-39	dBm	Launched into SMF
Extinction Ratio	ER	9			dB	PRBS 2 <sup>7</sup> -1 Test Pattern
Total Jitter	TJ			0.43	UI	PRBS 2 <sup>7</sup> -1 Test Pattern
Transmitter and Dispersion Penalty	TDP			2.3	dB	Transmit on 20km SMF
Optical Waveform Diagram	Compliant with IEEE Std 802.3ah™-2004					Figure 2, Mask Margin>5%

**GEPON Transmitter Electrical Characteristics**

Parameter	Symbol	Min	Typical	Max	Unit	Notes
Data Input Differential Swing		200		1600	mV	LVPECL input, AC Coupled
Input Differential Impedance		90	100	110	$\Omega$	
Transmitter Disable Voltage - Low		0		0.8	V	
Transmitter Disable Voltage - High		2.0		V <sub>CC</sub>	V	

### Transmitter Eye Mask Definitions and Test Procedure

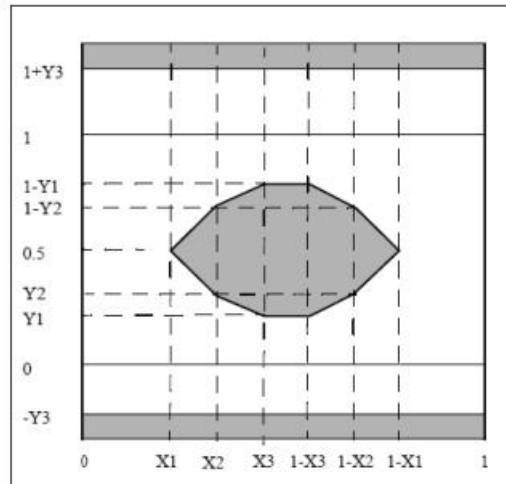

Figure 1: 10G EPON Transmitter Eye Mask Definitions

X1	X2	X3	Y1	Y2	Y3	Unit
0.25	0.40	0.45	0.25	0.28	0.40	UI

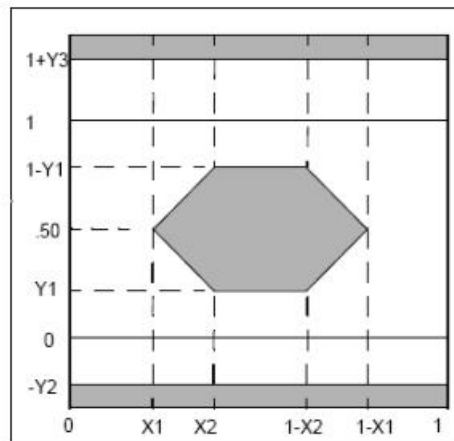

Figure 2: GEAPON Transmitter Eye Mask Definitions

X1	X2	Y1	Y2	Y3	Unit
0.22	0.375	0.20	0.20	0.30	UI

### 10GEPON Receiver Optical Characteristics

Parameter	Symbol	Min	Typical	Max	Unit	Notes
Operating Wavelength		1260		1280	nm	
Sensitivity	SEN			-28	dBm	PRBS 2 <sup>31</sup> -1 @10.3125Gbps BER ≤1×10 <sup>-3</sup>
Saturation Optical Power	SAT	-6			dBm	
LOS De-Assert Level				-29	dBm	
LOS Assert Level		-45			dBm	
Hysteresis		0.5		6	dB	

### 10GEPON Receiver Electrical Characteristics

Parameter	Symbol	Min	Typical	Max	Unit	Notes
Receiver Threshold Settling Time	T <sub>SETTLING</sub>			800	ns	Figure 3
Data Output Differential Swing		400		850	mV	CML output, DC coupled
LOS Assert Time				1024	ns	
LOS De-Assert Time				512	ns	
LOS Voltage - Low		0		0.4	V	
LOS Voltage - High		2.4		VCC+0.3	V	

### GEPON Receiver Optical Characteristics

Parameter	Symbol	Min	Typical	Max	Unit	Notes
Operating Wavelength		1260		1360	nm	
Sensitivity	SEN			-29.78	dBm	PRBS 2 <sup>7</sup> -1 @1.25Gbps BER ≤1×10 <sup>-12</sup>
Saturation Optical Power	SAT	-9.38			dBm	
LOS De-Assert Level				-31	dBm	
LOS Assert Level		-45			dBm	
Hysteresis		0.5		6	dB	



## GEPON Receiver Electrical Characteristics

Parameter	Symbol	Min	Typical	Max	Unit	Notes
Receiver Threshold Settling Time	$T_{SETTLING}$			256	ns	Figure 3
Data Output Differential Swing		600		1600	mV	LVPECL output, DC coupled
LOS Assert Time				1024	ns	
LOS De-Assert Time				512	ns	
LOS Voltage - Low		0		0.4	V	
LOS Voltage - High		2.4		VCC	V	
RSSI Trigger-Low		0		0.8	V	
RSSI Trigger-High		2.0		VCC	V	

## Timing Parameter Definitions in Burst Mode Sequence

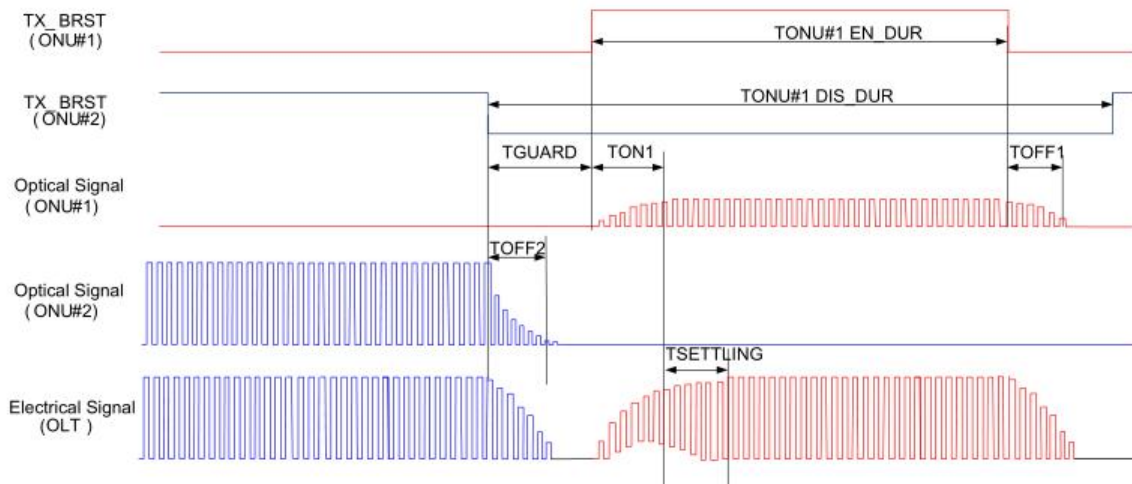

Figure 3: Timing Parameter Definitions in Burst Mode Sequence

### RSSI Characteristics

Parameter	Symbol	Min	Typical	Max	Unit	Notes
Optical Signal During Time	$T_{opt}$		1500		ns	
RSSI Trigger Width	$T_w$		500		ns	
RSSI Trigger Delay	$T_D$		300		ns	
I <sup>2</sup> C Access Prohibited Time				500	$\mu$ s	

### Digital RSSI Sample/Hold Timing Specification

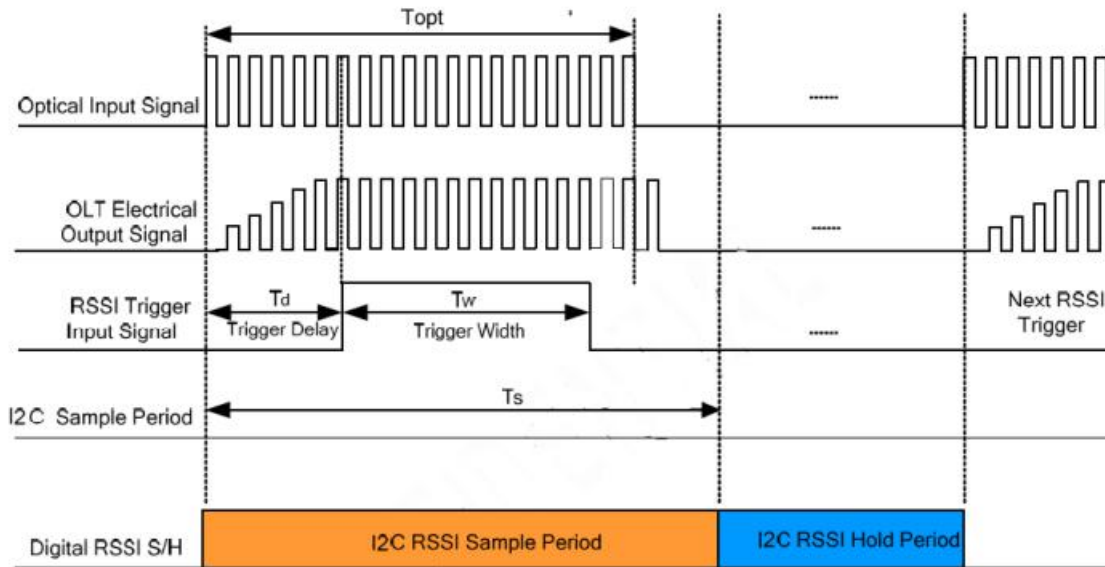

Figure 4 Timing Parameter Definitions in RSSI Trigger



## Pin Out Drawing

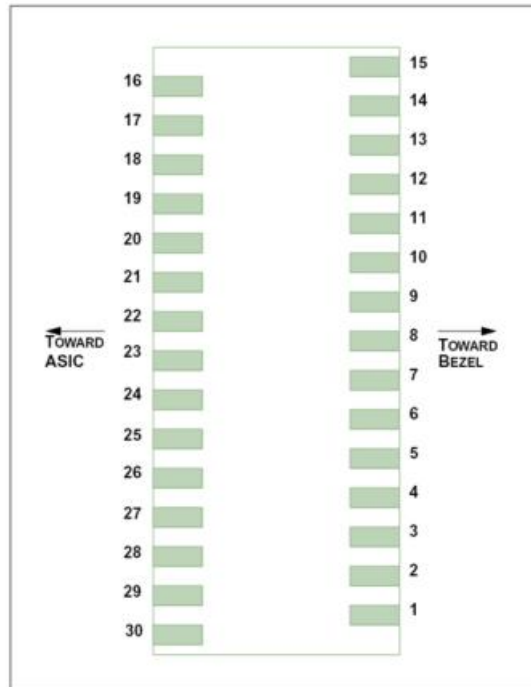

Figure 5: Pin Out Drawing

## Pin Description

PIN	Name	Description	Notes
1	GND	Module Ground	
2	TX-1G-P	Non-Inverted Transmit Data in	LVPECL input, AC coupled
3	TX-1G-N	Inverted Transmit Data in	LVPECL input, AC coupled
4	GND	Module Ground	
5	TX_DIS	Transmitter Disable	LVTTTL Input Low: transmitter on
6	VCC5	+5V Power Supply	
7	GND	Module Ground	
8	VCC3_TX	Transmitter 3.3V Power Supply	
9	VCC3_RX	Receiver 3.3V Power Supply	
10	SCL	The clock line	The clock line of two wire serial interface
11	SDA	The data line	The data line of two wire serial interface

12	MOD_ABS	Indicates Module is not present	Grounded in the Module
13	NC	Not Connected	
14	RX_LOS	RX_LOS Indication	LVTTTL output. Active High when the receiver
15	GND	Module Ground	
16	GND	Module Ground	
17	RD_10G_N	Inverted 10G Received Data Out	CML output, DC coupled
18	RD_10G_P	Non-inverted 10G Received Data Out	CML output, DC coupled
19	GND	Module Ground	
20	RD_1G_N	Inverted 1G Received Data Out	LVPECL Output, DC Coupled
21	RD_1G_P	Non-inverted 1G Received Data Out	LVPECL Output, DC Coupled
22	N.C.	Not be Connected in the transceiver	
23	RSSI_TRIG	RSSI Trigger for Transceiver	RSSI Trigger
24	N.C.	Not be Connected in the transceiver	
25	N.C	Not be Connected in the transceiver	
26	N.C	Not be Connected in the transceiver	
27	GND	Module Ground	
28	TX_10G_N-	Inverted Transmit Data in	CML input, AC coupled
29	TX_10G_P	Non-Inverted Transmit Data in	CML input, AC coupled
30	GND	Module Ground	

## Typical Interface Circuit

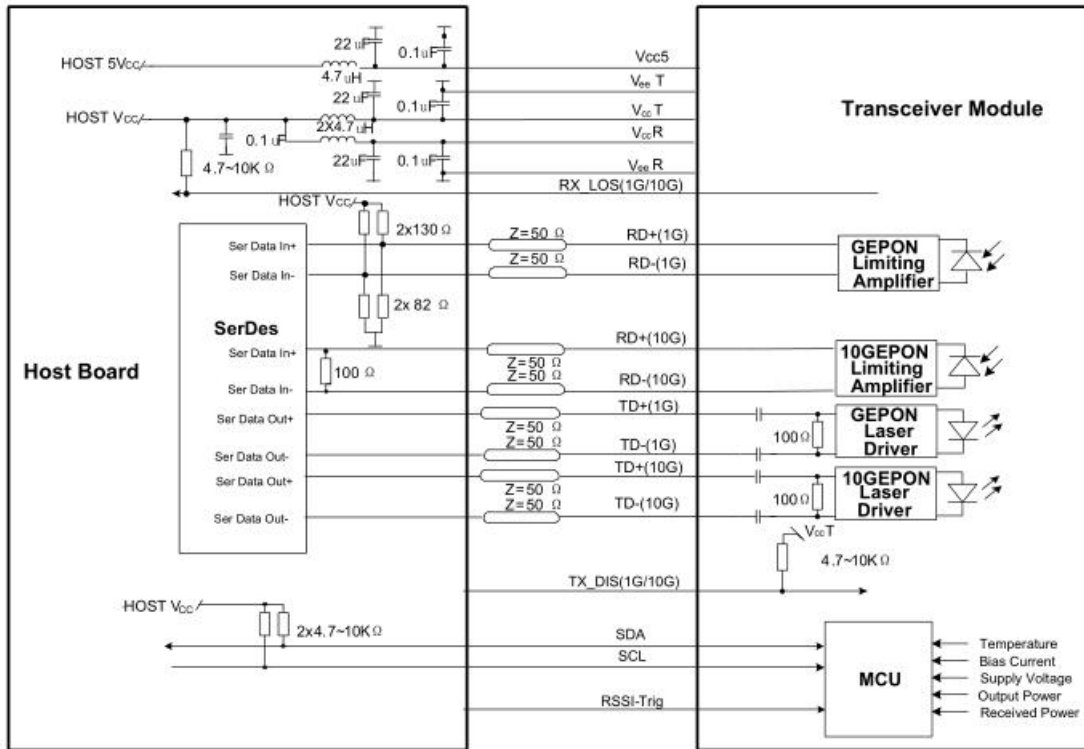

Figure 6: Typical Interface Circuit



## EEPROM Information

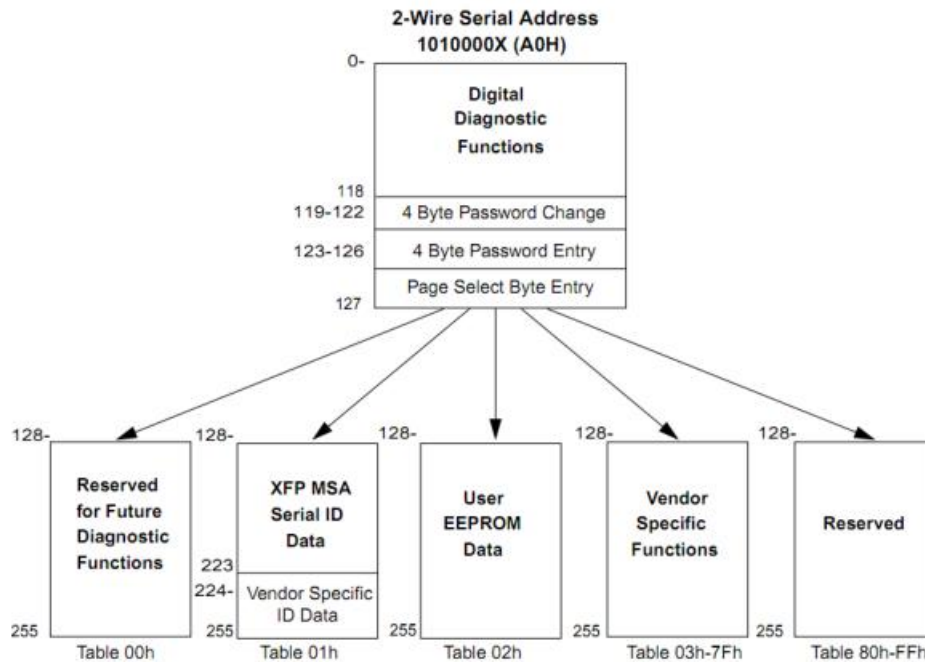

Figure 7: EEPROM Memory Map Specific Data Field Description

## Digital Diagnostic Monitoring Interface

Parameter	Range	Accuracy	Calibration	Notes
Temperature	0 to 70°C	±3°C	Internal	LSB: 1/256°C
Voltage	2.97 to 3.63V	±3%	Internal	LSB: 0.1mV
Bias Current_1G	0 to 131mA	±10%	Internal	LSB: 2uA
TX Power_1G	2 to 7dBm	±3dB	Internal	LSB: 0.1uW
Bias Current_10G	0 to 131mA	±10%	Internal	LSB: 2uA
TX Power_10G	2 to 5dBm	±3dB	Internal	LSB: 0.1uW
RX Power Monitor	-30 to -6dBm	±3dB	Internal	LSB: 0.1uW

## Package Outline

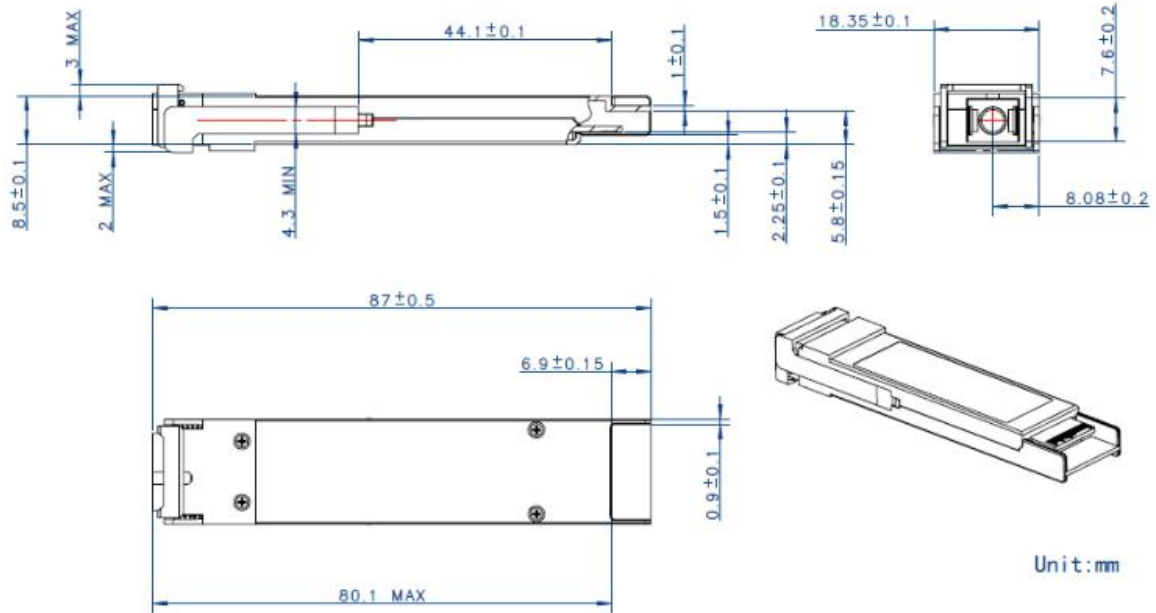

Figure 8: Package Outline

## Ordering Information

<b>Part Number</b>	10GEPON-OLT-XGS
<b>Application</b>	Symmetric 10GEPON OLT, with 1.25G TX/RX, 0°C~+70°C
<b>Wavelength (nm)</b>	1577T/1270R 1490T/1310R
<b>Data Rate (Gb/s)</b>	10.3T/10.3R 1.25T/1.25R
<b>ODN Class</b>	PR30
<b>Package</b>	XFP
<b>Connector</b>	SC